

STANDART KALIP ELEMENLARI

Standard Die Components

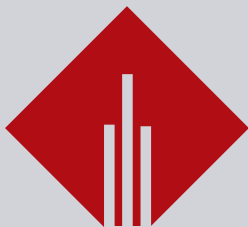

GNS

KALIP STANDARTLARI

KALIP VE İŞ PARÇASI BAĞLAMA ELAMANLARI

Mold and Workpiece Clamping Components



Sayfa 10

GMA501
BLOK YANDAN BAĞLAMA
Block Side Press



Sayfa 10

GMU501
BLOK YANDAN BAĞLAMA
Block Side Press



Sayfa 17

P1870
PUL
Washer



Sayfa 28

MP1290
MERDİVEN DIŞ BAĞLAMA PABUCU
Serrated Thread Clamp



Sayfa 11

TP1750
T-PABUÇ
T-Nut

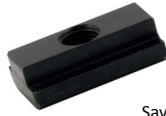

Sayfa 13

UP1710
UZUN T-PABUÇ
Long T-Nut



Sayfa 14

TS1790
TAKVİYELİ SOMUN
Hexagon Nut



Sayfa 16

PS1810
PULLU SOMUN
Nut with Washer

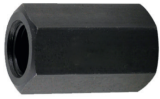

Sayfa 15

US1830
UZATMA SOMUN
Extension Nut

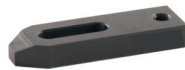

Sayfa 27

DP1330
DESTEK DELİKLİ DÜZ PABUÇ
Straight Clamp with Support Hole
Washer



Sayfa 29

PP1387
PLAKA BAĞLAMA PABUCU
Plate Sliding Clamp



Sayfa 23

SAS1610
SOMUNLU PULLU T-AYAKLI
SAPLAMA
T-Slot Bolt with Nut and Washer



Sayfa 20

TAS1590
T-AYAKLI SAPLAMA
T-Slot Bolt



Sayfa 18

DS1690
DÜZ SAPLAMA
Straight Stud



Sayfa 26

KAS1630
KOMBİNE T-AYAKLI SAPLAMA
Combined T-Slot Bolt



Sayfa 30

PC1490
PABUÇ DESTEK CIVATASI
Clamp Support Bolt



Sayfa 29

MD1310
MERDİVEN DIŞ DESTEK
Serrated Thread Support



Sayfa 31

TD1510
TRAPEZ DIŞ YÜKSELTİCİ DESTEK
Trapeze Thread Lifter Support



Sayfa 32

BS1990
VİDALI YÜKSELTİCİ BAĞLAMA SET
Screwed Coupling Set With Lifter



Sayfa 33

BS2010
MERDİVEN YÜKSELTİCİ BAĞLAMA
SET Coupling Set With Serrated V

BÖLÜM 1



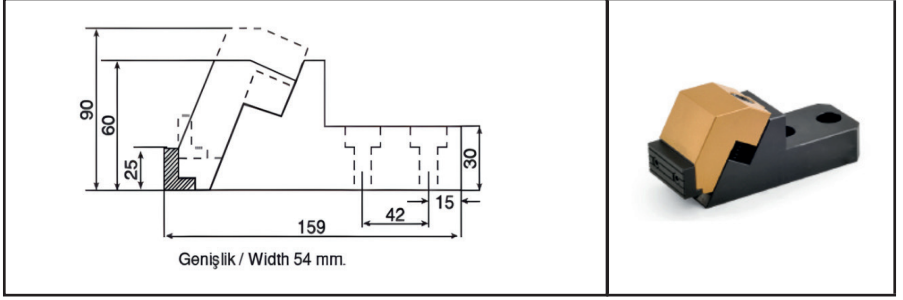

KALIP VE İŞ PARÇASI BAĞLAMA ELAMANLARI Mold and Workpiece Clamping Components

- GMAS01-GMUS01
- TP1750
- UP1710
- TS1790
- US1830
- PS1810
- P1870
- DS1690
- TAS1590
- SAS1610
- KAS1630
- DP1330
- MP1290
- PP1387
- MD1310
- PC1490
- TD1510
- BS1990
- BS2010
- Blok Yandan Bağlama
- T-Pabuç
- Uzun T-Pabuç
- Takviyeli Somun
- Uzatma Somun
- Pullu Somun
- Pul
- Düz Saplama
- T-Ayaklı Saplama
- Somunlu Pullu T-Ayaklı Saplama
- Kombine T-Ayaklı Saplama
- Destek Delikli Düz Pabuç
- Merdiven Dış Bağlama Pabucu
- Plaka Bağlama Pabucu
- Merdiven Dış Destek
- Pabuç Destek Civatası
- Trapez Dış Yükseltici Destek
- Vidalı Yükselticili Bağlama Set
- Merdiven Yükselticili Bağlama Set
- Block Side Press
- T-Nut
- Hong T-Nut
- Hexagon Nut
- Long T-Nut
- Nut with Washer
- Washer
- Straight Stud
- T-Slot Bolt
- T-Slot Bolt with Nut and Washer
- Combined T-Slot Bolt
- Straight Clamp with Support Hole
- Serrated Thread Clamp
- Plate Sliding Clamp
- Serrated Thread Support
- Clamp Support Bolt
- Trapeze Thread Lifter Support
- Screwed Coupling Set with Lifter
- Coupling Set with Serrated Hell Block



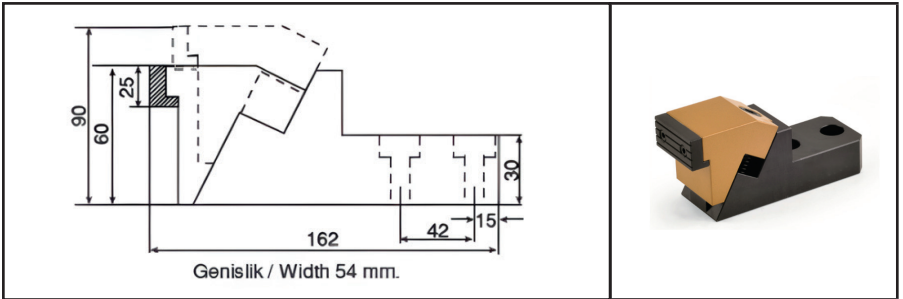

Kod - Code			Sıkma Kuvveti Clamping
GMAS-01-14	14	2,8	3000
GMAS-01-16	16	2,8	3000
GMAS-01-18	18	2,8	3000
GMAS-01-20	20	2,8	3000
GMAS-01-22	22	2,8	3000
GMAS-01-24	24	2,8	3000



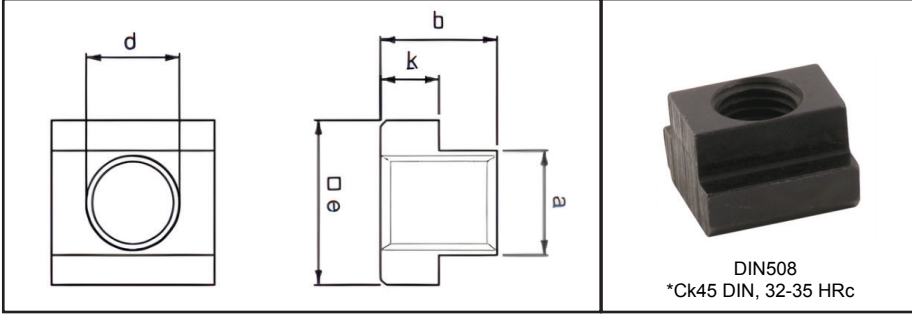

Kod - Code			Sıkma Kuvveti Clamping
GMUS-01-14	14	2,8	3000
GMUS-01-16	16	2,8	3000
GMUS-01-18	18	2,8	3000
GMUS-01-20	20	2,8	3000
GMUS-01-22	22	2,8	3000
GMAS-01-24	24	2,8	3000





Kod - Code	$d \times$ 	a	e	h	k	 (g)
TP1750 -0506	M5x6	5.7	10	8	4	4
TP1750 -0608	M6x8	7.7	13	10	6	10
TP1750 -0810	M8x10	9.7	15	12	6	12
TP1750 -0812	M8x12*	11.7	18	14	7	22
TP1750 -0814	M8x14*	13.7	22	16	8	40
TP1750 -0816	M8x16*	15.7	25	18	9	60
TP1750 -0818	M8x18*	17.7	28	20	10	90
TP1750 -1012	M10x12	11.7	18	14	7	20
TP1750 -1014	M10x14*	13.7	22	16	8	37
TP1750 -1016	M10x16*	15.7	25	18	9	55
TP1750 -1018	M10x18*	17.7	28	20	10	87

Tablonun Devamı Yan Sayfadadır.
The rest of the table is on the next page.

Kod - Code	 dx	a	e	h	k	 (g)
TP1750 -1214	M12x14	13.7	22	16	8	30
TP1750 -1216	M12x16*	15.7	25	18	9	55
TP1750 -1218	M12x18*	17.7	28	20	10	80
TP1750 -1416	M14x16	15.7	25	18	9	45
TP1750 -1418	M14x18*	17.7	28	20	10	75
TP1750 -1618	M16x18	17.7	28	20	10	65
TP1750 -1620	M16x20*	19.7	32	24	12	115
TP1750 -1622	M16x22*	21.7	35	28	14	170
TP1750 -1624	M16x24*	23.7	40	32	16	260
TP1750 -1628	M16x28*	27.7	44	36	18	375
TP1750 -1820	M18x20	19.7	32	24	12	105
TP1750-1822	M18x22*	21.7	35	28	14	160
TP1750-2022	M20x22	21.7	35	28	14	150
TP1750-2024	M20x24*	23.7	40	32	16	240
TP1750-2028	M20x28*	27.7	44	36	18	350
TP1750-2224	M22x24	23.7	40	32	16	220
TP1750-2228	M22x28*	27.7	44	36	18	330
TP1750-2428	M24x28	27.7	44	36	18	330
TP1750-2436	M24x36*	35.6	54	44	22	665
TP1750-3036	M30x36	35.6	54	44	22	585
TP1750-3642	M36x42	41,6	65	52	26	1025
TP1750-4248	M42x48	47,6	75	60	30	1600

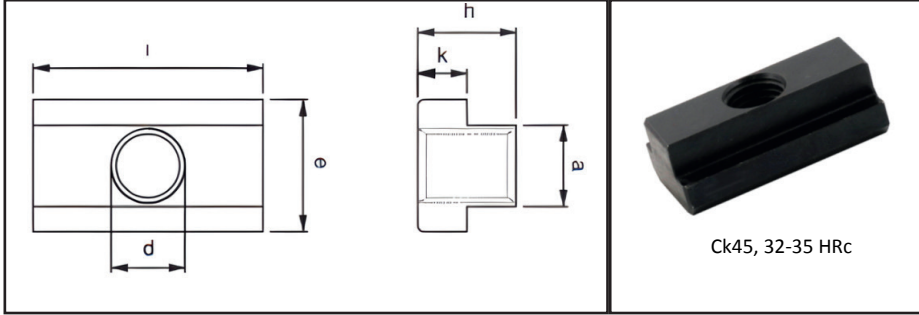
- -T –Pabucun mukavemeti için dişli kısmının tümüne vidalama yapılması gerekir.
- - Screwing must be done on the entire thread part for the endurance of T-Nut



Kod-Code	dx		a	e	L	h	k	 (g)
UP1710-0608	M6x8		7.7	13	26	10	6	14
UP1710-0810	M8x10		9.7	15	30	12	6	25
UP1710-1012	M10x12		11.7	18	36	14	7	49
UP1710-1214	M12x14		13.7	22	44	16	8	82
UP1710-1416	M14x16		15.7	25	50	18	9	120
UP1710-1618	M16x18		17.7	28	56	20	10	165
UP1710-1820	M18x20		19.7	32	64	24	12	260
UP1710-2022	M20x22		21.7	35	70	28	14	365
UP1710-2224	M22x24		23.7	40	80	32	16	535
UP1710-2428	M24x28		27.7	44	88	36	18	745
UP1710-3036	M30x36		35.6	54	108	44	22	1390

- T-Pabucun mukavemeti için dişli kısmının tümüne vidalama yapılması gerekir.
- Screwing must be done on the entire thread part for the endurance of T-Nut
- Hassas Makina Pleytlerinde "T" Kanalı Korur.
- This clamp protects T-Slot in sensitive machine plates

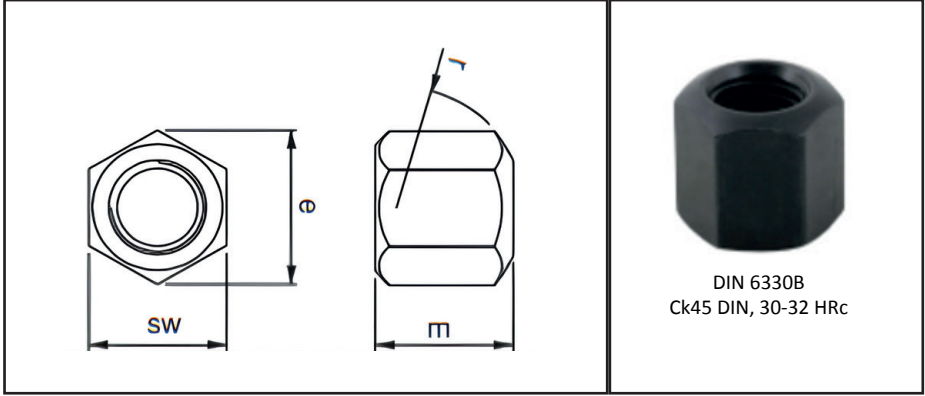

Kod-Code	Metrik	sw	e	m	r	 (g)
TS1790-06	M6	10	11.7	9	9	5
TS1790-08	M8	13	15	12	12	9
TS1790-10	M10	17	19.6	15	15	20
TS1790-12	M12	19	21.9	18	17	25
TS1790-14	M14	22	25.4	21	20	40
TS1790-16	M16	24	27.7	24	22	55
TS1790-18	M18	27	31.2	27	24	80
TS1790-20	M20	30	34.6	30	27	110
TS1790-22	M22	32	36.9	33	30	130
TS1790-24	M24	36	41.5	36	32	190
TS1790-30	M30	46	53.1	45	41	400
TS1790-36	M36	55	63.5	54	50	680
TS1790-42	M42	65	75	63	58	1150

- Düz yüzey DIN 6340 pul ile kullanılır.
- Flat surface is used with DIN 6340 Washer
- Radüslü yüzey DIN 6319D ve DIN 6319G pullar ile kullanılır.
- This nut is used with Rad-top surface DIN 6319D and DIN 6319G washers

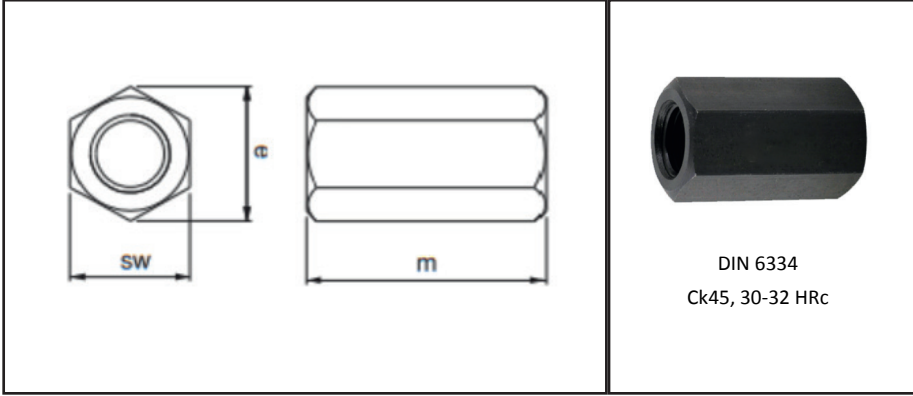

Kod-Code	Metrik	sw	e	m	 (g)
US1830-06	M6	10	11.7	18	8
US1830-08	M8	13	15	24	19
US1830-10	M10	17	19.6	30	40
US1830-12	M12	19	21.9	36	55
US1830-14	M14	22	25.4	42	90
US1830-16	M16	24	27.7	48	115
US1830-18	M18	27	31.2	54	165
US1830-20	M20	30	34.6	60	230
US1830-22	M22	32	36.9	66	245
US1830-24	M24	36	41.5	72	400
US1830-30	M30	46	53.1	90	840
US1830-36	M36	55	63.5	108	1430
US1830-42	M42	65	75	126	2330

- -DIN 787 T-Ayaklı saplama ve DIN 6379 düz saplamlarda uzatma amaçlı kullanılır.
- -It is used in DIN 787 T-Studs and DIN 6379 Straight Studs as extension.

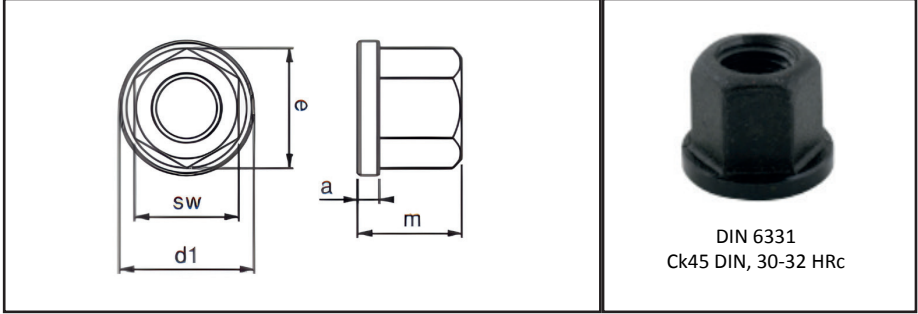

Kod-Code	Metrik	sw	e	m	a	d1	 (g)
PS1810-08	M8	13	14.7	12	3.5	18	12
PS1810-10	M10	17	19.2	15	4	22	25
PS1810-12	M12	19	21.5	18	4	25	30
PS1810-14	M14	22	24.9	21	4.5	28	50
PS1810-16	M16	24	27.2	24	5	31	65
PS1810-18	M18	27	30.6	27	5	34	90
PS1810-20	M20	30	34	30	6	37	130
PS1810-22	M22	32	36.3	33	6	40	155
PS1810-24	M24	36	40.8	36	6	45	220
PS1810-30	M30	46	52.3	45	8	58	465
PS1810-36	M36	55	62	54	10	68	500
PS1810-42	M42	65	75	63	12	80	1340

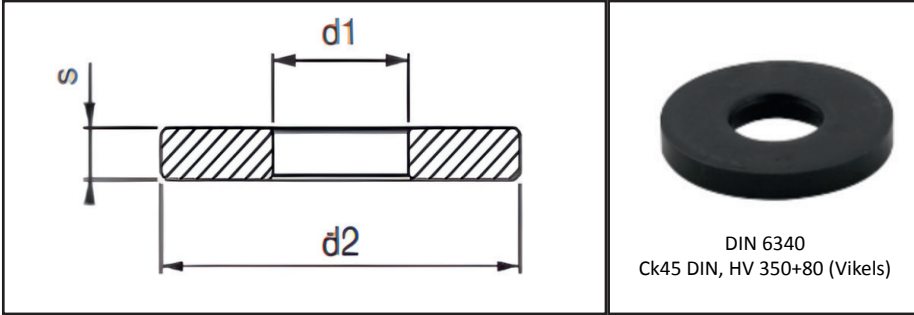

Kod-Code	Metrik	Withworth	d1	d2	s	 (g)
P1870-06	M6	1/4	6.4	17	3	6
P1870-08	M8	5/16	8.4	23	4	10
P1870-10	M10	3/8	10.5	28	4	16
P1870-12	M12	1/2	13	35	5	30
P1870-14	M14	-	15	40	5	40
P1870-16	M16	5/8	17	45	6	60
P1870-18	M18	-	19	45	6	60
P1870-20	M20	3/4	21	50	6	70
P1870-22	M22	7/8	23	50	8	90
P1870-24	M24	7/8	25	60	8	140
P1870-30	M30	1 1/8	31	68	10	215
P1870-36	M36	1 1/4	38	80	12	360
P1870-42	M42	1 1/2	44	98	15	640

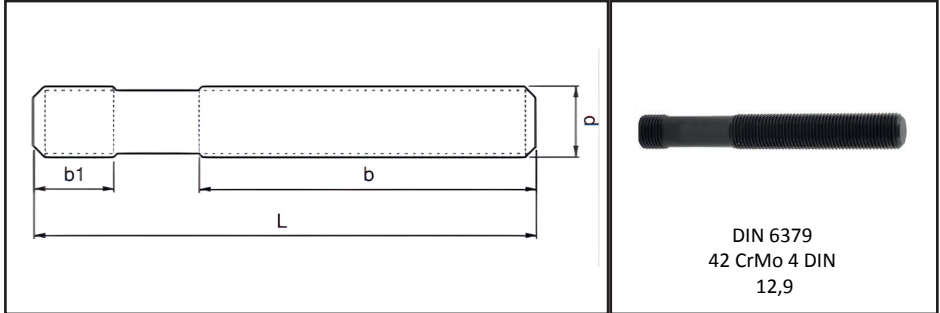

DIN 6379
42 CrMo 4 DIN
12,9

Sıkma Verileri

Tightening Data
Nm kN



Kod - Code	d	x	L	b1	b	Nm	kN	(g)
DS1690-08040	M8		x40	11	20	36	27	10
DS1690-08063			x63		40			15
DS1690-08080			x80		50			20
DS1690-08100			x100		63			30
DS1690-08125			x125		75			35
DS1690-08160			x160		100			45
DS1690-10050	M10		x50	13	25	67	43	20
DS1690-10063			x63		32			25
DS1690-10080			x80		50			35
DS1690-10100			x100		63			45
DS1690-10125			x125		75			55
DS1690-10160			x160		100			70
DS1690-10200	x200	125	95					
DS1690-12050	M12		x50	15	25	120	63	35
DS1690-12063			x63		32			40
DS1690-12080			x80		50			55
DS1690-12100			x100		63			70
DS1690-12125			x125		75			90
DS1690-12160			x160		100			115
DS1690-12200	x200	125	140					
DS1690-14063	M14		x63	17	32	191	86	60
DS1690-14080			x80		50			75
DS1690-14100			x100		63			95
DS1690-14125			x125		75			120
DS1690-14160			x160		100			150
DS1690-14200			x200		125			195
DS1690-14250	x250	160	240					
DS1690-16063	M16		x63	19	32	302	118	85
DS1690-16080			x80		50			105
DS1690-16100			x100		63			130
DS1690-16125			x125		75			160
DS1690-16160			x160		100			205
DS1690-16200			x200		125			260
DS1690-16250	x250	160	325					
DS1690-16315	x315	180	405					
DS1690-16500	x500	315	650					

Tablonun Devamı Yan Sayfadadır.
The rest of the table is on the next page.



Sıkma Verileri
Tightening Data
Nm kN



Kalın İş Parçası
Bağlantı
Elemanları

Kod - Code	d	x	L	b1	b	Nm	kN	(g)
DS1690-18080	M18		x80	23	50	405	144	130
DS1690-18100			x100		60			160
DS1690-18125			x125		75			200
DS1690-18160			x160		100			260
DS1690-18200			x200		125			320
DS1690-18250			x250		150			400
DS1690-18315			x315		180			510
DS1690-20080	M20		x80	27	32	580	184	155
DS1690-20100			x100		60			200
DS1690-20125			x125		70			250
DS1690-20160			x160		100			330
DS1690-20200			x200		125			400
DS1690-20250			x250		160			510
DS1690-20315			x315		200			640
DS1690-20400			x400		250			815
DS1690-20500			x500		315			1020
DS1690-22100	M22		x100	31	45	772	228	250
DS1690-22125			x125		70			305
DS1690-22160			x160		100			400
DS1690-22200			x200		125			500
DS1690-22250			x250		160			620
DS1690-22315			x315		180			780
DS1690-22400			x400		250			1010
DS1690-24100	M24		x100	35	45	994	265	290
DS1690-24125			x125		70			365
DS1690-24160			x160		100			470
DS1690-24200			x200		125			580
DS1690-24250			x250		160			730
DS1690-24315			x315		200			920
DS1690-24400			x400		250			1170
DS1690-24500			x500		315			1470
DS1690-24630			x630		315			1860
DS1690-30125	M30		x125	43	56	1930	421	570
DS1690-30200			x200		125			910
DS1690-30250			x250		160			1150
DS1690-30315			x315		200			1435
DS1690-30500			x500		315			2315
DS1690-30700			x700		400			3215
DS1690-301000			x1000		400			4700
DS1690-36160			M36					x160
DS1690-36200	x200	125		1340				
DS1690-36250	x250	160		1710				
DS1690-36315	x315	200		2150				
DS1690-36400	x400	250		2700				
DS1690-36500	x500	315		3450				
DS1690-36700	x700	400		4750				
DS1690-42315	M42			x315		59	200	5415
DS1690-42400			x400	250	3750			
DS1690-42500			x500	315	4690			

- Not:150 °C üzerindeki ortamlarda sıkma işlemi yapılırken dişlerin üzerine Loctite 8150 kullanılır.
- Note: Environments on the 150 °C when clamping action on the thread Loctite 8150 is used.

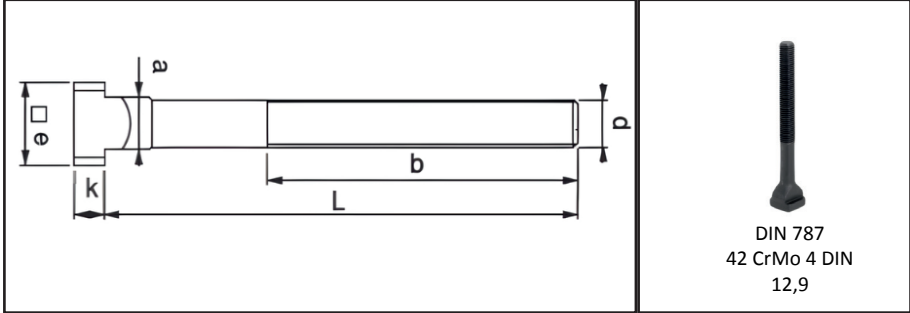

Kod - Code	dx	xL	b	a	e	k	Sıkma Verileri Tightening Data		g
							Nm	kN	
TAS1590-0606025	M6x6	x25	15	5.7	10	4	17	17	8
TAS1590-0606025		x40	28						11
TAS1590-0606025		x63	40						15
TAS1590-0808032	M8x8	x32	22	7.7	12	6	43	32	13
TAS1590-0808050		x50	35						16
TAS1590-0808080		x80	50						20
TAS1590-1010040	M10x10	x40	23	9.7	15	6	79	51	35
TAS1590-1010063		x63	45						45
TAS1590-1010080		x80	50						60
TAS1590-1010100		x100	60						70
TAS1590-1012050	M10x12	x50	35	11.7	18	7	79	51	50
TAS1590-1012063		x63	40						60
TAS1590-1012080		x80	55						65
TAS1590-1012100		x100	60						75
TAS1590-1012125		x125	75						90
TAS1590-1012160		x160	90						105
TAS1590-1012200		x200	120						120
TAS1590-1212050	M12x12	x50	35	11.7	18	7	141	74	65
TAS1590-1212063		x63	40						70
TAS1590-1212080		x80	55						80
TAS1590-1212100		x100	65						100
TAS1590-1212125		x125	75						110
TAS1590-1212160		x160	100						140
TAS1590-1212200		x200	120						160
TAS1590-1214050	M12x14	x50	35	13.7	22	8	141	74	80
TAS1590-1214063		x63	45						90
TAS1590-1214080		x80	55						100
TAS1590-1214100		x100	65						110
TAS1590-1214125		x125	75						135
TAS1590-1214160		x160	100						160
TAS1590-1214200		x200	120						180

Tablonun Devamı Yan Sayfadadır.
The rest of the table is on the next page.



TAS1590-1416063	x63	45						115
TAS1590-1416080	x80	55						140
TAS1590-1416100	x100	65						160
TAS1590-1416125	M14x16 x125	75	15.7	25	9	223	101	180
TAS1590-1416160	x160	100						220
TAS1590-1416200	x200	120						255
TAS1590-1416250	x250	150						300
TAS1590-1616063	x63	45						140
TAS1590-1616080	x80	55						160
TAS1590-1616100	x100	65						190
TAS1590-1616125	M16x16 x125	85	15.7	25	9	354	138	225
TAS1590-1616160	x160	100						270
TAS1590-1616200	x200	120						315
TAS1590-1616250	x250	150						380
TAS1590-1618063	x63	45						170
TAS1590-1618080	x80	55						185
TAS1590-1618100	x100	65						220
TAS1590-1618125	M16x18 x125	85	17.7	28	10	354	138	245
TAS1590-1618160	x160	100						295
TAS1590-1618200	x200	120						340
TAS1590-1618250	x250	150						405
TAS1590-1820080	x80	55						260
TAS1590-1820100	x100	65						290
TAS1590-1820125	x125	85						340
TAS1590-1820160	M18x20 x160	110	19.7	32	12	474	169	390
TAS1590-1820200	x200	125						455
TAS1590-1820250	x250	150						535
TAS1590-1820315	x315	190						650
TAS1590-2020080	x80	55						300
TAS1590-2020100	x100	65						330
TAS1590-2020125	x125	85						380
TAS1590-2020160	M20x20 x160	110	19.7	32	12	679	215	450
TAS1590-2020200	x200	125						535
TAS1590-2020250	x250	160						635
TAS1590-2020315	x315	190						760
TAS1590-2022080	x80	55						345
TAS1590-2022100	x100	65						380
TAS1590-2022125	x125	85						435
TAS1590-2022160	M20x22 x160	110	21.7	35	14	679	215	500
TAS1590-2022200	x200	125						590
TAS1590-2022250	x250	160						695
TAS1590-2022315	x315	190						820

- Not:150 °C üzerindeki ortamlarda sıkma işlemi yapılırken dişlerin üzerine Loctite 8150 kullanılır.
- Note: Environments on the 150 °C when clamping action on the thread Loctite 8150 is used.

TAS1590-2224080	x80	55							465
TAS1590-2224100	x100	65							515
TAS1590-2224125	x125	85							580
TAS1590-2224160	x160	110	23.7	40	16	903	266		660
TAS1590-2224200	x200	125							775
TAS1590-2224250	x250	150							805
TAS1590-2224315	x315	190							1050
TAS1590-2424100	x100	70							550
TAS1590-2424125	x125	85							630
TAS1590-2424160	x160	110							725
TAS1590-2424200	x200	125	23.7	40	16	1163	310		850
TAS1590-2424250	x250	150							990
TAS1590-2424315	x315	190							1180
TAS1590-2424400	x400	240							1410
TAS1590-2428100	x100	70							660
TAS1590-2428125	x125	85							730
TAS1590-2428160	x160	110							820
TAS1590-2428200	x200	125	27.7	44	18	1163	310		950
TAS1590-2428250	x250	150							1090
TAS1590-2428315	x315	190							1300
TAS1590-2428400	x400	240							1530
TAS1590-2428500	x500	290							1800
TAS1590-3036125	x125	80							1280
TAS1590-3036160	x160	110							1440
TAS1590-3036200	x200	135	35.6	54	22	2258	493		1620
TAS1590-3036250	x250	150							1880
TAS1590-3036315	x315	200							2150
TAS1590-3036500	x500	300							3010
TAS1590-3642160	x160	100							2260
TAS1590-3642250	x250	175	41.6	65	26	3953	719		2890
TAS1590-3642400	x400	250							4010
TAS1590-3642600	x600	340							5900
TAS1590-4248160	x160	100							3550
TAS1590-4248250	x250	175	47.6	75	30	6337	986		4530
TAS1590-4248400	x400	250							6160

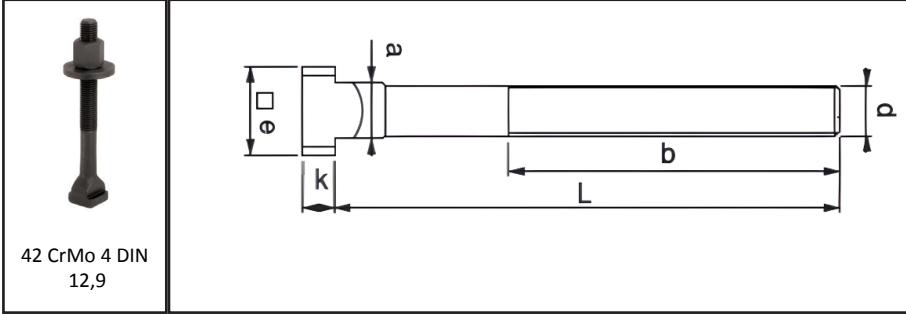

42 CrMo 4 DIN
12,9

Kalip İş Parçası
Bağlantı
Elemanları

Kod - Code	dx	xL	b	a	e	k	Tightening Data Sıkma Verileri		
							Nm	kN	
SAS1610-0606025	M6x6	x25	15	5.7	10	4	17	17	19
SAS1610-0606025		x40	28						25
SAS1610-0606025		x63	40						36
SAS1610-0808032	M8x8	x32	22	7.7	12	6	43	32	39
SAS1610-0808050		x50	35						45
SAS1610-0808080		x80	50						56
SAS1610-1010040	M10x10	x40	23	9.7	15	6	79	51	65
SAS1610-1010063		x63	45						80
SAS1610-1010080		x80	50						90
SAS1610-1010100		x100	60						110
SAS1610-1012050	M10x12	x50	35	11.7	18	7	79	51	85
SAS1610-1012063		x63	40						95
SAS1610-1012080		x80	55						100
SAS1610-1012100		x100	60						110
SAS1610-1012125		x125	75						125
SAS1610-1012160		x160	90						140
SAS1610-1012200		x200	120						160
SAS1610-1212050	M12x12	x50	35	11.7	18	7	141	74	120
SAS1610-1212063		x63	40						128
SAS1610-1212080		x80	55						140
SAS1610-1212100		x100	65						160
SAS1610-1212125		x125	75						170
SAS1610-1212160		x160	100						195
SAS1610-1212200		x200	120						220

Tablonun Devamı Yan Sayfadadır.
The rest of the table is on the next page.



Kod - Code	dx	xL	b	a	e	k	Tightening Data Sıkma Verileri		(g)
							Nm	kN	
SAS1610-1214050	M12x14	x50	35	13.7	22	8	223	101	140
SAS1610-1214063		x63	45						150
SAS1610-1214080		x80	55						155
SAS1610-1214100		x100	65						175
SAS1610-1214125		x125	75						195
SAS1610-1214160		x160	100						220
SAS1610-1214200		x200	120						240
SAS1610-1416063	M14x16	x63	45	15.7	25	9	354	138	200
SAS1610-1416080		x80	55						230
SAS1610-1416100		x100	65						245
SAS1610-1416125		x125	75						270
SAS1610-1416160		x160	100						310
SAS1610-1416200		x200	120						340
SAS1610-1416250		x250	150						390
SAS1610-1616063	M16x16	x63	45	15.7	25	9	354	138	260
SAS1610-1616080		x80	55						285
SAS1610-1616100		x100	65						310
SAS1610-1616125		x125	85						345
SAS1610-1616160		x160	100						385
SAS1610-1616200		x200	120						435
SAS1610-1616250		x250	150						505
SAS1610-1618063	M16x18	x63	45	17.7	28	10	354	138	290
SAS1610-1618080		x80	55						305
SAS1610-1618100		x100	65						340
SAS1610-1618125		x125	85						370
SAS1610-1618160		x160	100						415
SAS1610-1618200		x200	120						460
SAS1610-1618250		x250	150						525
SAS1610-1820080	M18x20	x80	55	19.7	32	12	474	169	405
SAS1610-1820100		x100	65						435
SAS1610-1820125		x125	85						480
SAS1610-1820160		x160	110						535
SAS1610-1820200		x200	125						610
SAS1610-1820250		x250	150						680
SAS1610-1820315		x315	190						790
SAS1610-2020080	M20x20	x80	55	19.7	32	12	679	215	480
SAS1610-2020100		x100	65						515
SAS1610-2020125		x125	85						570
SAS1610-2020160		x160	110						635
SAS1610-2020200		x200	125						725
SAS1610-2020250		x250	160						820
SAS1610-2020315		x315	190						950
SAS1610-2022080	M20x22	x80	55	21.7	35	14	679	215	530
SAS1610-2022100		x100	65						565
SAS1610-2022125		x125	85						620
SAS1610-2022160		x160	110						690
SAS1610-2022200		x200	125						775
SAS1610-2022250		x250	150						880
SAS1610-2022315		x315	190						1050

Tablonun Devamı Yan Sayfadadır.
The rest of the table is on the next page.

Tightening Data
Sıkma Verileri

Kod - Code

Kod - Code	dx	xL	b	a	e	k	Nm	kN	(g)
SAS1610-2224080		x80	55						700
SAS1610-2224100		x100	65						740
SAS1610-2224125		x125	85						805
SAS1610-2224160	M22x24	x160	110	23.7	40	16	903	206	890
SAS1610-2224200		x200	125						1000
SAS1610-2224250		x250	150						1115
SAS1610-2224315		x315	190						1280
SAS1610-2424100		x100	70						885
SAS1610-2424125		x125	85						970
SAS1610-2424160	M24x24	x160	110	23.7	40	16	1163	310	1060
SAS1610-2424200		x200	125						1180
SAS1610-2424250		x250	150						1320
SAS1610-2424315		x315	190						1515
SAS1610-2424400		x400	240						1750
SAS1610-2428100		x100	70						1000
SAS1610-2428125		x125	85						1065
SAS1610-2428160	M24x28	x160	110	27.7	44	18	1163	310	1150
SAS1610-2428200		x200	125						1280
SAS1610-2428250		x250	150						1425
SAS1610-2428315		x315	190						1640
SAS1610-2428400		x400	240						1870
SAS1610-2428500		x500	290						2170
SAS1610-3036125		x125	80						1900
SAS1610-3036160		x160	110						2065
SAS1610-3036200	M30x36	x200	135	35.6	54	22	2258	493	2250
SAS1610-3036250		x250	150						2500
SAS1610-3036315		x315	200						2770
SAS1610-3036500		x500	300						3630
SAS1610-3642160		x160	100						3310
SAS1610-3642250	M36x42	x250	175	41.6	65	26	3953	719	3930
SAS1610-3642400		x400	250						5010
SAS1610-3642600		x600	340						6900
SAS1610-4248160		x160	100						4600
SAS1610-4248250	M42x48	x250	175	47.6	75	30	6337	986	5600
SAS1610-4248400		x400	250						7200

Kalıp İş Parçası
Bağlantı
Elemanları

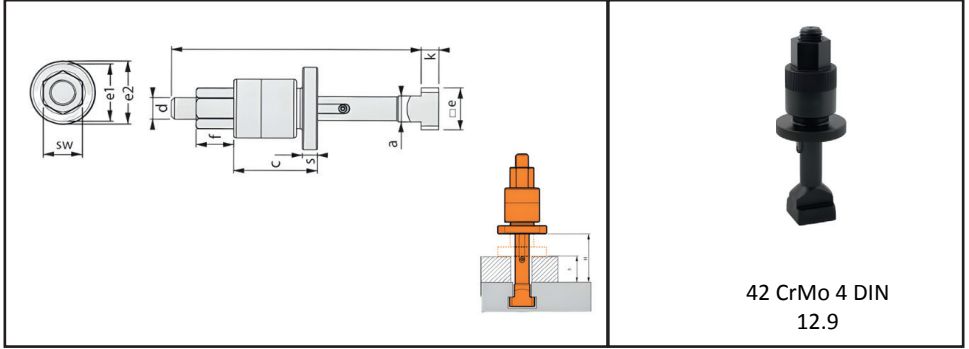

Kod - Code	dx	xl		a	e	k	h-H	e1	e2	c	s	f	sw	Nm	kN
KAS1630-2022200	M20x22x200	1635	21.7	35	14	25-75	49	69	92	12	30	30	679	215	
KAS1630-2022250	M20x22x250	1720	21.7	35	14	70-120	49	69	92	12	30	30	679	215	
KAS1630-2424200	M24x24x200	2075	23.7	40	16	25-75	53	74	92	12	30	36	1163	310	
KAS1630-2424250	M24x24x250	2250	23.7	40	16	70-120	53	74	92	12	30	36	1163	310	
KAS1630-2428200	M24x28x200	2180	27.7	44	18	25-75	53	74	92	12	30	36	1163	310	
KAS1630-2428250	M24x28x250	2340	27.7	44	18	70-120	53	74	92	12	30	36	1163	310	
KAS1630-3036200	M30x36x200	3660	35.6	54	22	25-75	68	88	94	14	30	46	2258	493	
KAS1630-3036250	M30x36x250	3910	35.6	54	22	70-120	68	88	94	14	30	46	2258	493	

- Ağır preslerde , büyük kalıplarda çalışma esnasında vibrasyondan kaynaklanan olabilecek gevşemeyi somunun kontrastında sıkma yapısından dolayı önler.
- It prevents loosening due to vibration during operation in heavy presses and large molds, due to the nut's counter tightening structure.
- Not:150 °C üzerindeki ortamlarda sıkma işlemi yapılırken dişlerin üzerine Loctite 8150 kullanılır.
- Note: Environments on the 150 °C when clamping action on the thread Loctite 8150 is used.

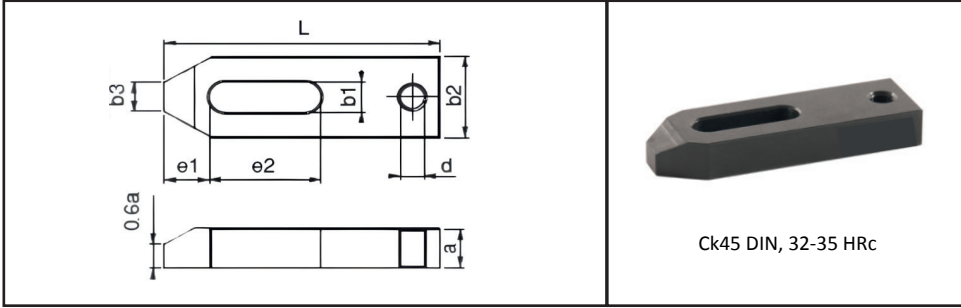

Ck45 DIN, 32-35 HRc

Kod - Code	L	b1	Metrik	Withworth	a	b2	b3	e1	e2	d	(g)
DP1330-06050	50	6.6	M6	1/4	10	20	8	10	20	M8	50
DP1330-08060	60	9	M8	5/16	12	25	10	13	22	M8	105
DP1330-10080	80	11	M10	3/8	15	30	12	15	30	M10	210
DP1330-12100	100	14.5	M12-M14	1/2	20	40	14	21	40	M12	465
DP1330-12125	125	14.5	M12-M14	1/2	20	40	14	21	50	M12	590
DP1330-16125	125	18.5	M16-M18	5/8	25	50	18	26	45	M16	930
DP1330-16160	160	18.5	M16-M18	5/8	25	50	18	26	65	M16	1200
DP1330-20160	160	22.5	M20-M22	3/4	30	60	22	30	60	M20	1710
DP1330-20200	200	22.5	M20-M22	3/4	30	60	22	30	80	M20	2170
DP1330-20250	250	22.5	M20-M22	3/4	35	70	30	30	100	M20	3885
DP1330-24160	160	26	M24	1	30	70	26	35	60	M24	1965
DP1330-24200	200	26	M24	1	35	70	26	35	80	M24	2920
DP1330-24250	200	26	M24	1	35	70	26	35	100	M24	3720
DP1330-24315	315	26	M24	1	40	80	35	35	100	M24	6435
DP1330-30250	250	33	M30	1 1/4	40	80	34	45	100	M24	4825
DP1330-30315	315	33	M30	1 1/4	50	80	34	45	130	M24	7665
DP1330-36400	400	43	M36-M42	1 1/2	58	100	43	100	150	M30	14490

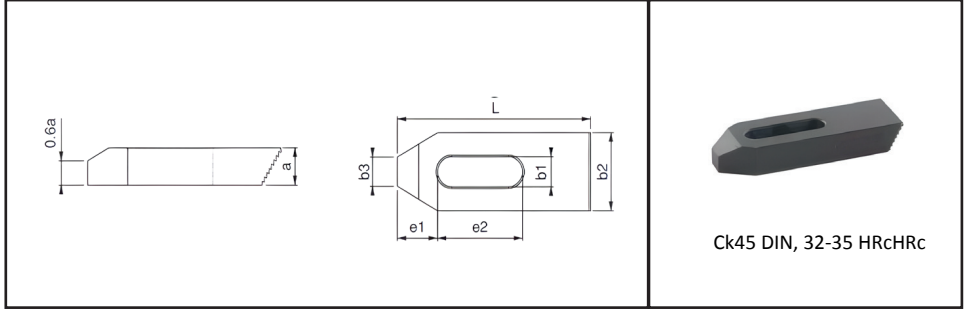

Kod-code	L	b1	metrik	withworth	a	b2	b3	e1	e2	
MP1290-06050	50	6.6	M6	1/4	10	20	8	10	20	50
MP1290-06080	80	6.6	M6	1/4	10	20	8	10	30	95
MP1290-08060	60	9	M8	5/16	12	25	10	13	22	100
MP1290-08100	100	9	M8	5/16	12	25	10	13	45	170
MP1290-10080	80	11	M10	3/8	15	30	12	15	30	190
MP1290-10100	100	11	M10	3/8	15	30	12	15	45	225
MP1290-12100	100	14.5	M12-M14	1/2	20	40	14	21	45	435
MP1290-12125	125	14.5	M12-M14	1/2	20	40	14	21	55	580
MP1290-16125	125	18.5	M16-M18	5/8	25	50	18	26	55	855
MP1290-16160	160	18.5	M16-M18	5/8	25	50	18	26	65	1175

- MD1310 Merdiven destek ile kullanılır.
- Product is used with MD1310 Serrated Support .

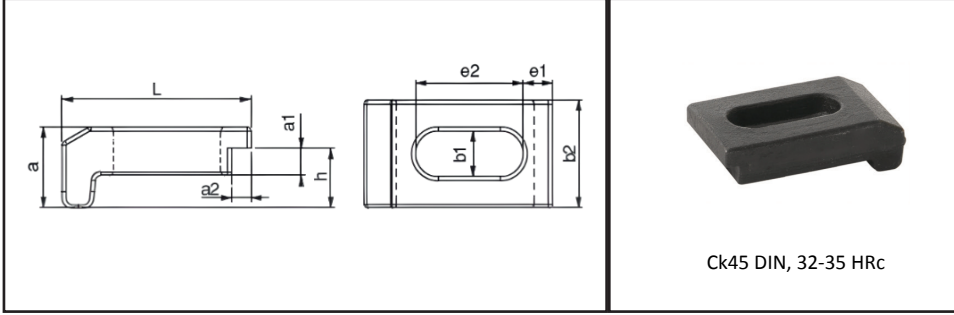

Kod - Code	L	b1	Metrik	Withworth	a	b2	a1x2	e1	e2	h	
PP1387-12070	70	13	M12	1/2	21.5	40	8x6	11	40	14	255
PP1387-16070	70	17	M16	5/8	29.5	40	10x7	11	40	22	290

- Yükselticisiz çalışma özelliği avantajı sağlar.
- Provides the advantage of working without support.

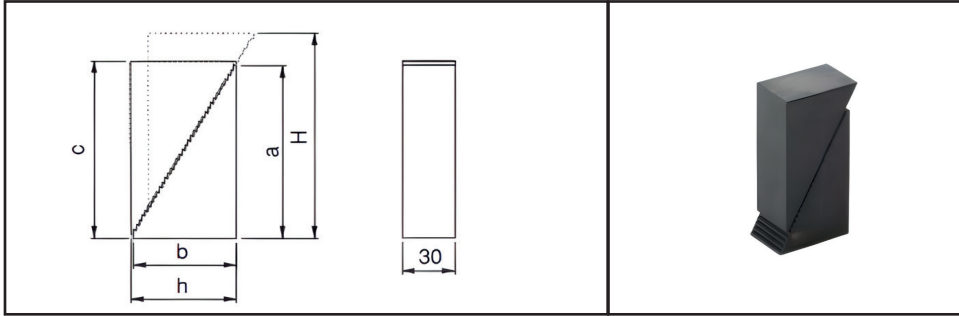
 MD1310
 MERDİVEN DIŞ DESTEK
 Serrated Thread Support





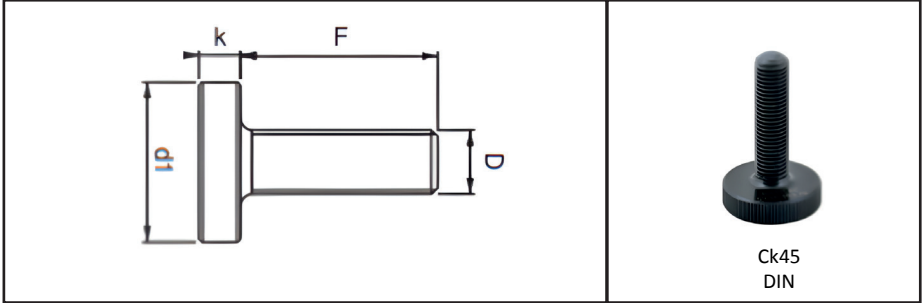

Kod-Code	h-H	a	b	c	Min-Max	
MD1310-01	37-85	57	35	60	0-40	505
MD1310-02	48-112	73	45	76	0-60	825
MD1310-03	58-139	90	55	93	0-75	1250
MD1310-04	66-165	108	64	111	0-90	1685

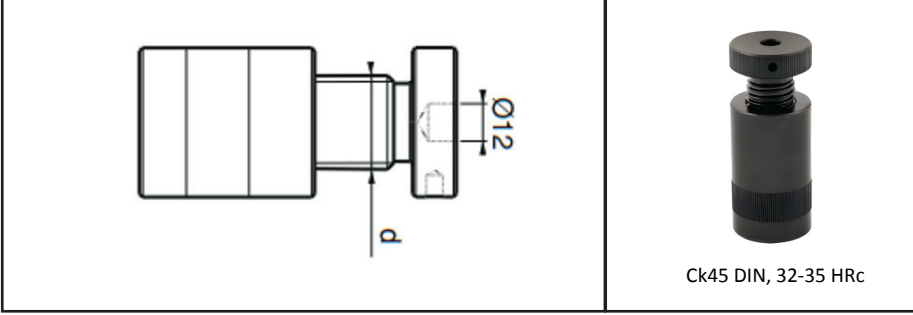
- MP1290 Merdiven dış pabuç ile kullanılır.
- Product is used with MP1290 Serrated Thread Clamp







Kod - Code	D x f	d1	k	 (g)
PC1490-08032	M8x32	25	8	40
PC1490-10042	M10x42	30	8	60
PC1490-12050	M12x50	36	10	110
PC1490-12095	M12x95	36	10	150
PC1490-16062	M16x62	45	13	240
PC1490-16097	M16x97	45	13	285
PC1490-16117	M16x117	45	13	310
PC1490-20062	M20x62	50	13	320
PC1490-20097	M20x97	50	13	390
PC1490-20117	M20x117	50	13	430
PC1490-24081	M24x81	50	14	445
PC1490-24116	M24x116	50	14	555
PC1490-30180	M30x180	70	24	1650

Ck45 DIN, 32-35 HRc

Kod - Code		d			 kgf	 (g)
TD1510-023030	23-30	M16	34	32	1000	140
TD1510-040060	40-60	M16	34	32	1800	250
TD1510-042052	42-52	Tr30x4	50	50	6000	570
TD1510-050070	50-70	Tr30x4	50	50	6000	680
TD1510-070100	70-100	Tr30x4	50	50	6000	960
TD1510-100140	100-140	Tr30x4	50	50	6000	1395
TD1510-140220	140-220	Tr30x4	54	54	6000	2285
TD1510-210330	210-330	Tr30x6	58	58	8000	3950
TD1510-260430	260-430	Tr30x6	68	68	8000	7250

- TD1510 yükselticiler DIN 6314-6315-6316 pabuçlarda yükseltici destek amaçlı kullanılır.
- TD1510 Lifters are used in DIN 6314-6315-6316 clamps as the lifter support

Referans Nr.				d x L	DIN 6379
BS1990-1012	M10x12	265x255	6,44	M10x80-100-160-200	
BS1990-1214	M12x14	305x255	8,72	M12x80-100-160-200	
BS1990-1416	M14x16	435x255	12,98	M14x80-100-160-200	
BS1990-1618	M16x18	435-255	16,3	M16x80-100-160-200	
BS1990-1820	M18x20	495x255	17,82	M18x80-100-160-200	
BS1990-2022	M20x22	540x255	23,10	M20x100-125-160-200	



Ürün nr. BS1990 Vidalı Yükselticili Bağlama Set

Tabla Üzerine iş parçası ve aparatların hızlı ve güvenli bir şekilde bağlanması için çelik mamülden üretilmiş parçalardan oluşan bağlama seti.

Product Nr. BS1990 Screwed Coupling Set With Lifter

This is the coupling set produced from steel product in order to couple the work piece or apparatuses on the table in a rapid and safe way



Nr.	L	b1		a	e2	b2
DP1330	80	11	M10	15	30	30
DP1330	100 125	14,5	M12-M14	20	40	40
DP1330	125 160	18,5	M16-M18	25	45 65	50
DP1330	160 200	22,5	M20-M22	30	60 80	60

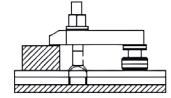
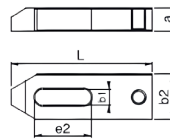

DIN 508

DIN 6330 B

Nr. US 1830

DIN 6331

DIN 6340

12	M10	M10	M10	M10	M10
14	M12	M12	M12	M12	M12
16	M16	M14	M14	M14	M14
18	M18	M16	M16	M16	M16
20	M19	M18	M18	M18	M18
22	M20	M20	M20	M20	M20

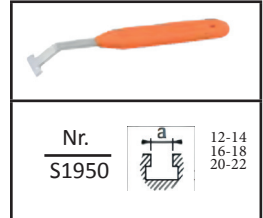

Nr.
S1950



12-14
16-18
20-22

Nr.	h	H	d	D
TD1510	23	30	M16	34
TD1510	40	60	M16	34
TD1510	70	100	Tr 30x4	50
TD1510	100	140	Tr 30x4	50

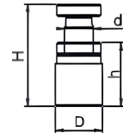





Ürün:52 Parça Vida Yükselticili İş Bağlama Set

- 6 adet DIN 508 T-Pabuç (M20x22 4 adet)
- 16 adet DIN 6379 saplama
- 6 adet DIN 6330B Takviyeli Somun
- 4 adet DIN 6331 pullu somun
- 2 adet US1830 uzatma somun
- 4 adet DIN 6340 Kalın Pul
- 4 adet Nr. DP1330 Destek delikli pabuç
- 8 adet Nr. TD1510 Vida diş yükseltici destek
- 1 adet Nr. S1950 T-Kanal temizleyici
- 1 adet statik boyalı çelik set

Product: 52 Piece set of Screwed Coupling Set With Lifter

- 6 pieces of DIN 508 T-Nut (M20x22 4 piece)
- 16 pieces of DIN 6379 Stud
- 6 pieces of DIN 6330B Supported Nut
- 4 pieces of DIN 6331 Nut with Washer
- 2 pieces of US 1830 Extension Nut
- 4 pieces of DIN 6340 Thick Washer
- 4 pieces of No. DP1330 Clamp with support hole
- 8 pieces of No. TD1510 Screw Thread Lifter Support
- 1 pieces of No. S1950 T-Slot Scraper
- 1 pieces of steel set with statical paint

Referans Nr.				$d \times L$	DIN 6379 
BS2010-1012	M10x12	330x255	7,27	M10x80-100-160-200	
BS2010-1214	M12x14	380x255	9,26	M12x80-100-160-200	
BS2010-1416	M14x16	435x255	12,29	M14x80-100-160-200	
BS2010-1618	M16x18	435x255	15,62	M16x80-100-160-200	
BS2010-1820	M18x20	495x255	18	M18x80-100-160-200	



Ürün nr. BS2010 Merdiven Yükselticili Bağlama Set

Tabla Üzerine iş parçası ve aparatların hızlı ve güvenli bir şekilde bağlanması için çelik mamülden üretilmiş parçalardan oluşan bağlama seti.

Product Nr. BS2010 Coupling Set With Serrated Hell Block

This is the coupling set produced from steel product in order to couple the work piece or apparatuses on the table in a rapid and safe way



Nr	L	b1		a	e2	b2
MP1290	80 100	11	M10	15	30 45	30
MP1290	100 125	14,5	M12-M14	20	45 55	40
MP1290	125 160	18,5	M16-M18	25	65 65	50

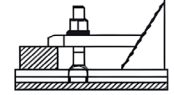
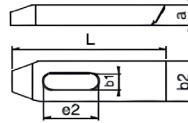

DIN 508

DIN 6330 B

Nr. US 1830

DIN 6331

DIN 6340

12	M10	M10	M10	M10	M10
14	M12	M12	M12	M12	M12
16	M16	M14	M14	M14	M14
18	M18	M16	M16	M16	M16
20	M19	M18	M18	M18	M18
22	M20	M20	M20	M20	M20

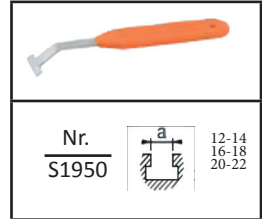

Nr.	h-H	a	min-max
MD1310	37-85	57	0-40
MD1310	48-112	73	0-60
MD1310	58-139	90	0-75
MD1310	66-165	108	0-90

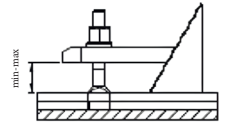
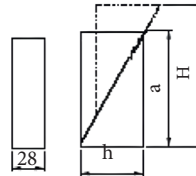

Ürün:52 Parça Merdiven Destekli İş Bağlama Set

- 6 adet DIN 508 T-Pabuç (M20x22 4 adet)
- 16 adet DIN 6379 saplama
- 6 adet DIN 6330B Takviyeli Somun
- 4 adet DIN 6331 pullu somun
- 2 adet US1830 uzatma somun
- 4 adet Nr. MP1290 merdiven pabuç
- 8 adet Nr. MD1310 merdiven diş de stok
- 1 adet Nr. S1950 T-Kanal temizleyici
- 1 adet statik boyalı çelik set

Product: 52 Piece set of Coupling set with serrated He II Block

- 6 pieces of DIN 508 T-Nut (M20x22 4 piece)
- 16 pieces of DIN 6379 Stud
- 6 pieces of DIN 6330B Supported Nut
- 4 pieces of DIN 6331 Nut with Washer
- 2 pieces of US1830 Extension Nut
- 4 pieces of No. MP1290 Serrated Clamp
- 8 pieces of No. MD1310 Clamp with support hole
- 1 pieces of No. S1950 T-Slot Scraper
- 1 pieces of steel set with statical paint



2002
Kuruluş - Sınc

100*

Genesis Kalıp Aparat Mühendislik San. ve Tic. Ltd. Şti



www.gnskalip.com



Üçevler Küçük Sanayi
Sitesi 21.Sk. 34.Blok
No:71 16130 Nilüfer
BURSA / TÜRKİYE



+90 0533 435 44 52
info@gnskalip.com



GNS
KALIP STANDARTLARI